

# Illustration Auswurf-träger fangkorb

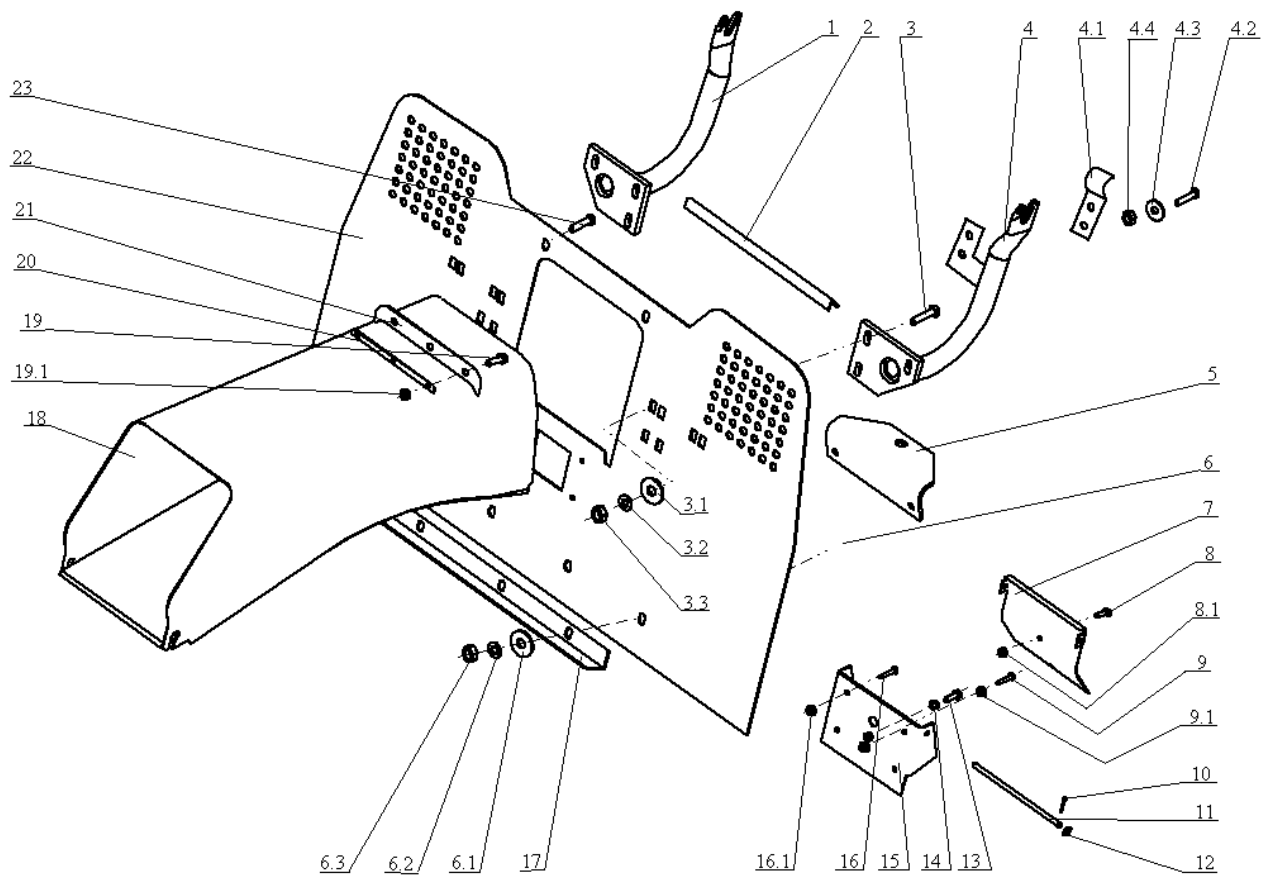

## Illustration    Auswurf-träger fangkorb

---

Bild Nr.	St.- Zahl	Teile Nr.	Beschreibung
1	1	SG532974432233	Halter
2	1	SG532096362013	Dichtung
3	6	SG947309578012	Sechskantschraube
3.1	6	SG947311210503	Scheibe
3.2	6	SG947311214502	Scheibe
3.3	6	SG947311120502	Mutter
4	1	SG532974432213	Halter
4.1	1	SG532097452243	Feder
4.2	2	SG947309203539	Schraube
4.3	2	SG947311210501	Scheibe
4.4	2	SG947311129515	Sichermutter
5	1	SG532113402453	Halter
6	4	SG947309578011	Sechskantschraube
6.1	4	SG947311210503	Scheibe
6.2	4	SG947311214502	Scheibe
6.3	4	SG947311120502	Mutter
7	1	SG532085352033	Schlüssel
8	1	SG947309019520	Schraube
8.1	2	SG947311120530	Sechskantmutter
9	1	SG947309203559	Schraube
9.1	1	SG947311120513	Sechskantmutter
10	2	SG947311338514	Stift
11	1	SG947532150531	Stift
12	2	SG947311210502	Scheibe
13	1	SG947309231529	Schraube
14	1	SG947315231195	Feder
15	1	SG532913462413	Halter
16	4	SG947309203539	Schraube
16.1	4	SG947311129515	Sichermutter
17	1	SG532113403233	Halter
18	1	SG532974472263	Auswurfschacht
19	3	SG947309231502	Schraube
19.1	3	SG947311120505	Mutter
20	1	SG532115308573	Scheibe
21	1	SG532113322813	Halter
22	1	SG532974422173	Deflector
23	2	SG947309503005	Schraube

# Illustration    Eletrischeteile

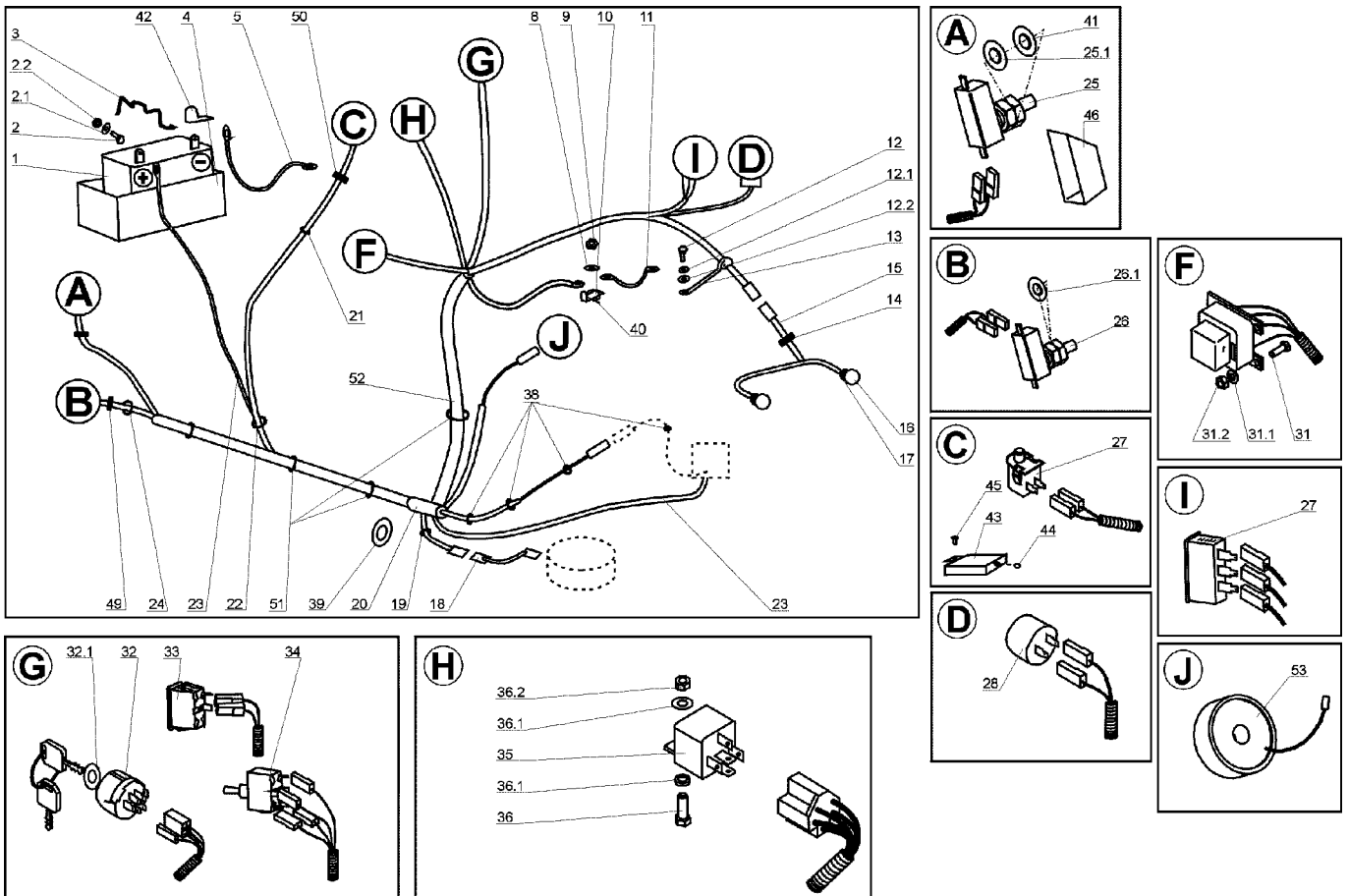

## Illustration    Elektrischeile

Bild Nr.	St.- Zahl	Teile Nr.	Beschreibung
1	1	SG947346211006	Batterie
2	2	SG947309203502	Sechskantschraube
2.1	2	SG947311210502	Scheibe
2.2	2	SG947311129513	Sichermutter
3	1	SG947532880041	Klemme
4	1	SG947232130001	Batteriekasten
5	1	SG947341271021	Kabel
8	1	SG947311210501	Scheibe
9	1	SG947311129515	Sichermutter
10	1	SG532113402583	Halter
11	1	SG947341271006	Anzeiger
12	1	SG947309203504	Schraube
12.1	1	SG947311214502	Scheibe
12.2	1	SG947311210503	Scheibe
13	1	SG947532150125	Halter
14	1	SG947532150211	Klemme
15	1	SG947341271036	Kabel
16	2	SG947347224006	Glühlampe
17	2	SG947443953001	Klemme
18	1	SG947341271052	Diode
19	1	SG947273121029	Buchse
20	1	SG947341271101	Kabel
21	1	SG947273121036	Buchse
22	1	SG947273121036	Buchse
23	1	SG947341271049	Anzeiger
24	2	SG947321841071	Klammer
25	1	SG947358113026	Schalter
25.1	1	SG947311210505	Scheibe
26	1	SG947358113026	Schalter
26.1	2	SG947311210505	Scheibe
27	1	SG947000532079	Sitz
28	1	SG947443312021	Warnlicht
31	2	SG947309203548	Schraube
31.1	4	SG947311210501	Scheibe
31.2	2	SG947311129515	Sichermutter
32	1	SG947443861005	Sperre
32.1	1	SG532092207513	Scheibe
33	2	SG947345329013	Schalter
34	1	SG947000532039	Schalter
35	1	SG947443811004	Relais
36	1	SG947309203548	Schraube
36.1	1	SG947311210501	Scheibe
36.2	1	SG947311129515	Sichermutter
38	4	SG947321841071	Klammer
39	1	SG947532150055	Deckel
40	1	SG947532150207	Ring

# Illustration    Eletrischeile

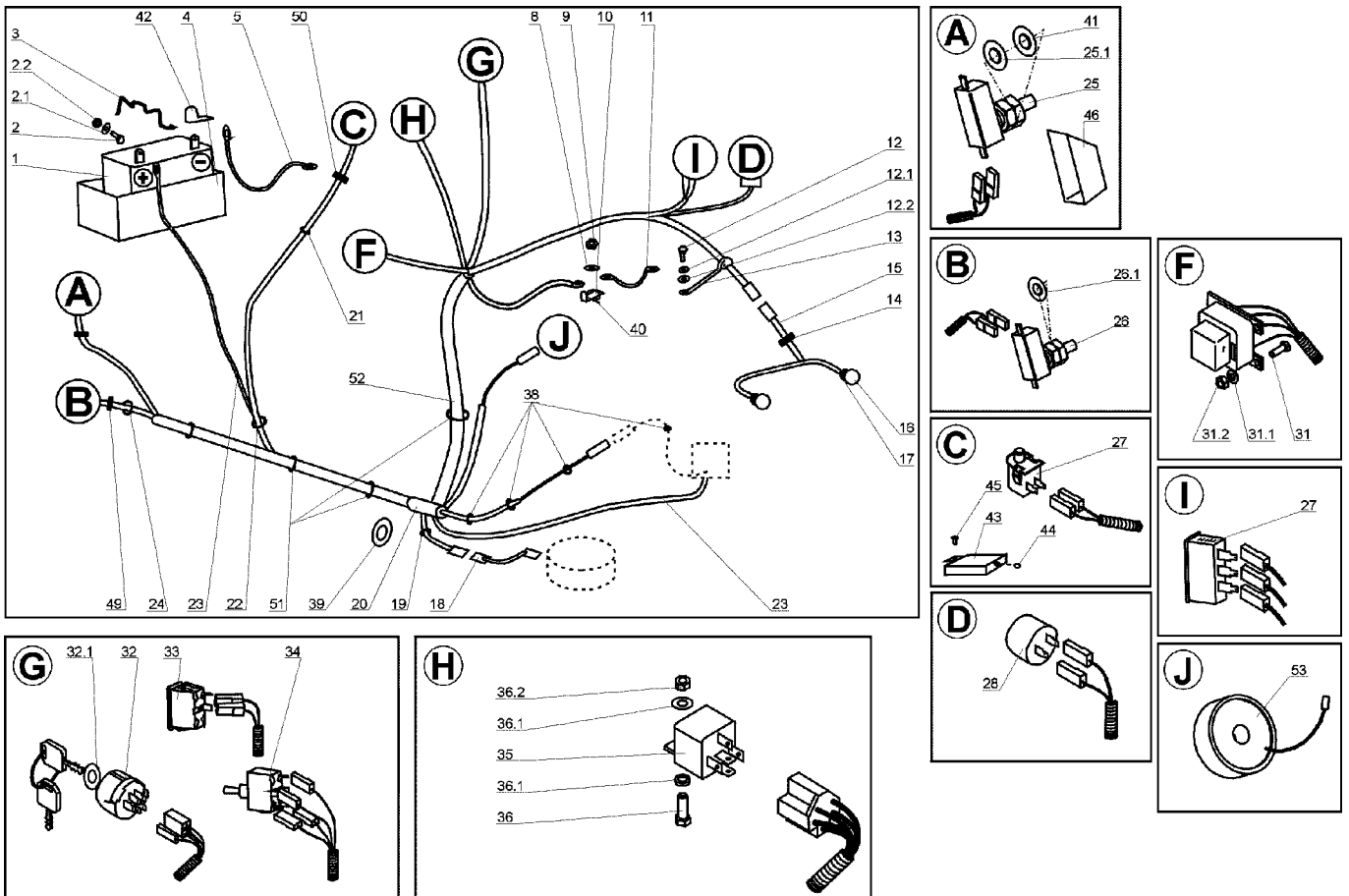

## Illustration    Eletrischeteile

---

Bild Nr.	St.- Zahl	Teile Nr.	Beschreibung
41	1	SG947311219498	Scheibe
42	2	SG947273125006	Klemme
43	1	SG532085427153	Sitz
44	1	SG947273121035	Durchfuhrung
45	1	SG947311691001	Niete
46	1	SG532085427173	Deckel
49	2	SG947532150211	Klemme
50	1	SG947532150211	Klemme
51	4	SG947532150207	Ring
52	1	SG947286134002	Rohr
53	1	SG947358352009	Tempogerat

# Illustration Getriebe

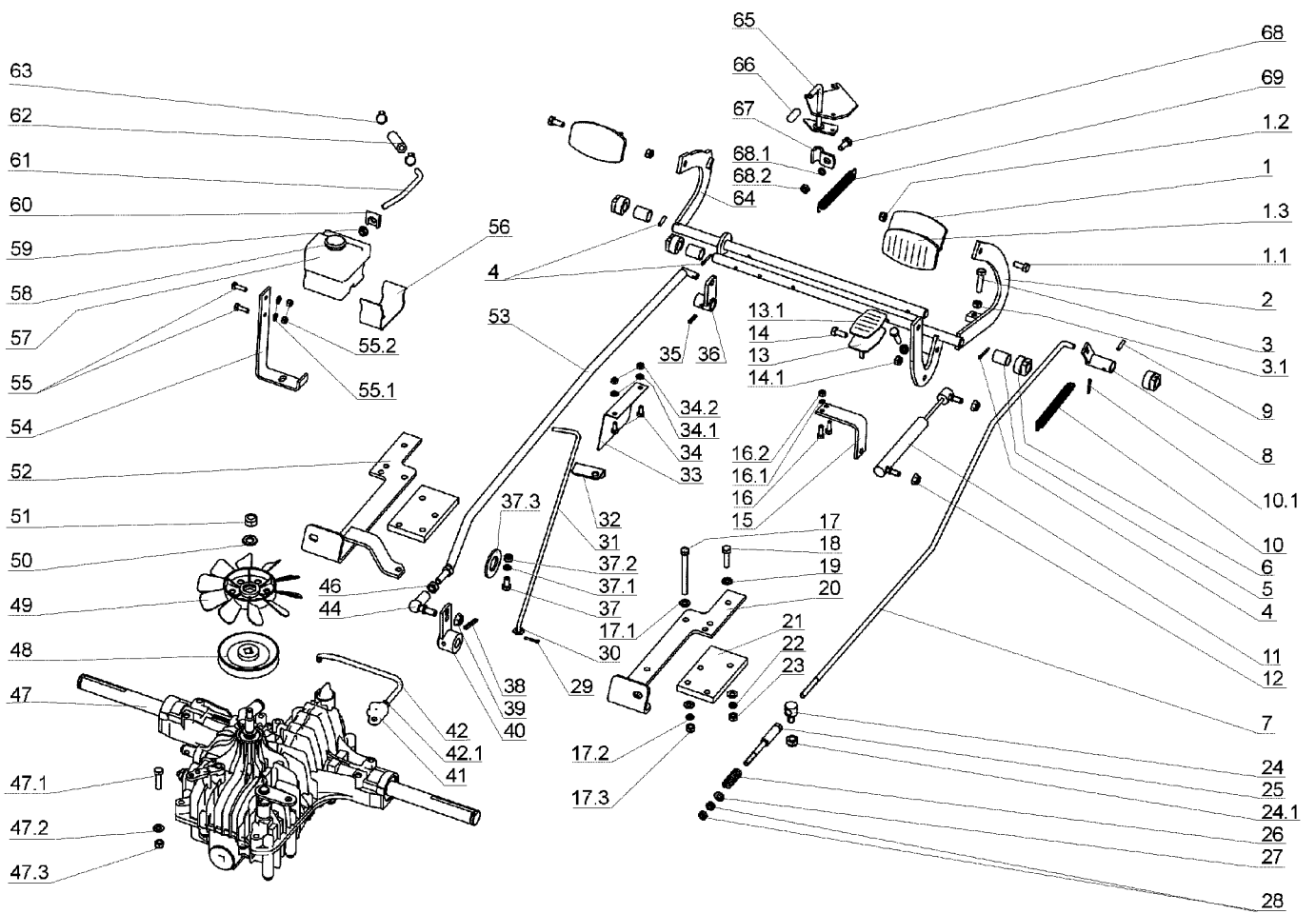

## Illustration    Getriebe

Bild Nr.	St.- Zahl	Teile Nr.	Beschreibung
1	2	SG532980512573	Fusshebel
1.1	2	SG947309203504	Schraube
1.2	2	SG947311129501	Sichermutter
1.3	2	SG947273151001	Pedalgummi
2	1	SG532980442213	Hebel
3	2	SG947309203530	Schraube
3.1	2	SG947311120502	Mutter
4	3	SG947311338517	Splint
5	3	SG947532150541	Buchse
6	4	SG947722643023	Buchse
7	1	SG532080422503	Anschluss
8	1	SG532980365183	Kupplungsblock
9	1	SG947315238037	Splint
10	1	SG947315231161	Feder
10.1	1	SG947311338501	Splint
11	1	SG947532150169	Stosshaempfer
12	2	SG947311129501	Sichermutter
13	1	SG532980512583	Fusshebel
13.1	1	SG947273151011	Fusshebel
14	1	SG947309203504	Schraube
14.1	1	SG947311129501	Sichermutter
15	1	SG532014408573	Halter
16	2	SG947309503557	Sechskantschraube
16.1	2	SG947311129513	Sichermutter
16.2	2	SG947311210502	Scheibe
17	4	SG947309201524	Sechskantschraube
17.1	8	SG947311210503	Scheibe
17.2	4	SG947311214502	Scheibe
17.3	4	SG947311120502	Mutter
18	4	SG947309503543	Sechskantschraube
19	8	SG947311210503	Scheibe
20	1	SG532113403863	Halter
21	2	SG532013312113	Scheibe
22	4	SG947311214502	Scheibe
23	4	SG947311120502	Mutter
24	1	SG947532150507	Schraube
24.1	1	SG947311129502	Mutter
25	1	SG532980112083	Schraube
26	1	SG947315231240	Feder
27	1	SG947311212517	Scheibe
28	2	SG947311120520	Mutter
29	1	SG947311338513	Splint
30	1	SG947311210502	Scheibe
31	1	SG532080412963	Spannstange
32	1	SG532113403993	Halter
33	1	SG532113308233	Deckel



# Illustration Getriebe

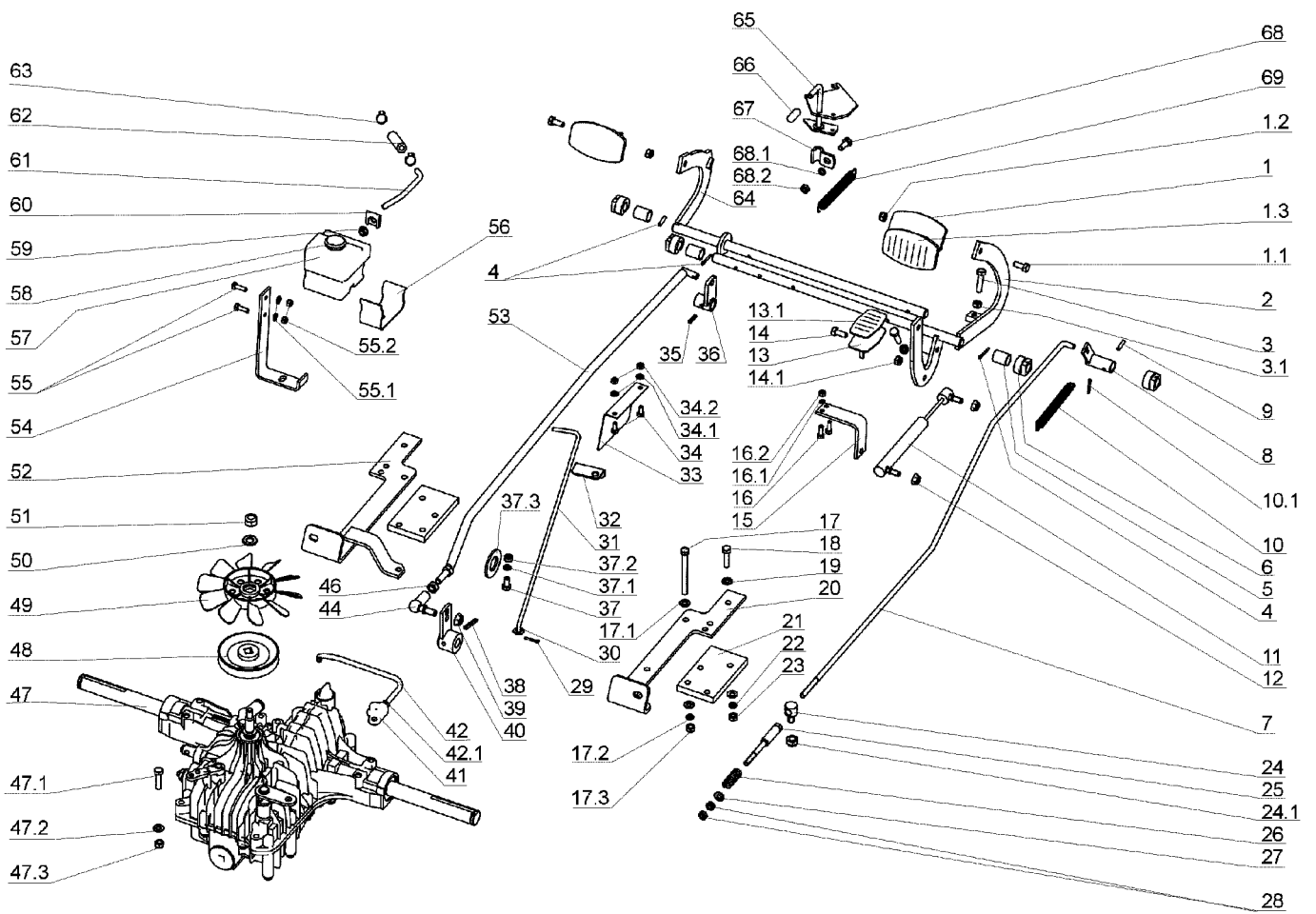

## Illustration    Getriebe

Bild Nr.	St.- Zahl	Teile Nr.	Beschreibung
34	2	SG947309203540	Sechskantschraube
34.1	2	SG947311210502	Scheibe
34.2	2	SG947311129513	Sichermutter
35	1	SG947315238037	Splint
36	1	SG532980364823	Arm
37	1	SG947309203503	Schraube
37.1	1	SG947311214502	Scheibe
37.2	1	SG947311120502	Mutter
37.3	1	SG947532150422	Ring
38	1	SG947315238049	Splint
39	1	SG947311129516	Mutter
40	1	SG532929462053	Hebel-komplet
41	1	SG532082472073	Flansch
42	1	SG532082402153	Rohrleitung
42.1	1	SG947311120538	Mutter
44	1	SG947442073021	Dichtung
46	1	SG947311150506	Mutter
47	1	SG947532991054	Getriebe
47.1	1	SG947309503556	Schraube
47.2	1	SG947311210503	Scheibe
47.3	1	SG947311129501	Sichermutter
48	1	SG947532150415	Scheibe
49	1	SG947532150414	Lufferrad
50	1	SG947311212507	Scheibe
51	1	SG947311129502	Mutter
52	1	SG532913368523	Halter
53	1	SG532980422123	Hebel
54	1	SG532113414193	Halter
55	2	SG947309503557	Sechskantschraube
55.1	2	SG947311210502	Scheibe
55.2	2	SG947311129513	Sichermutter
56	1	SG947532150375	Halter
57	1	SG947532150372	Tank
58	1	SG947532150374	Ventil
59	1	SG947532150373	Dichtung
60	1	SG532092402543	Ring
61	1	SG532082412143	Rohrleitung
62	1	SG532199202423	Schlauch
63	2	SG947548241016	Klammer
64	1	SG532980442263	Bremsepedal
65	1	SG532980712323	Hebel
66	1	SG947532150209	Stecker
67	1	SG532080412363	Halter
68	1	SG947309503518	Schraube
68.1	1	SG947311214502	Scheibe
68.2	1	SG947311120502	Mutter

# Illustration Getriebe

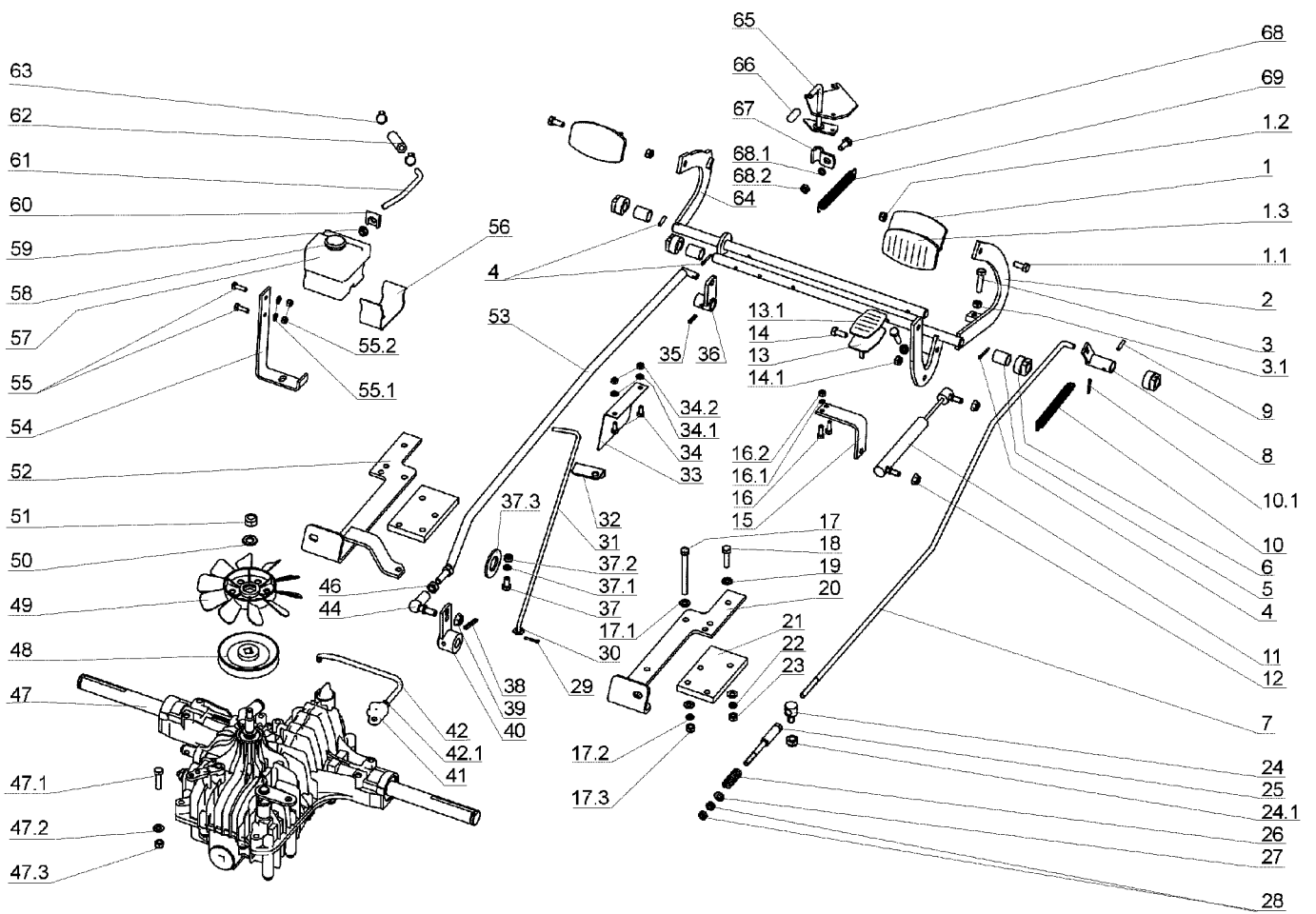

## Illustration    Getriebe

---

Bild Nr.	St.- Zahl	Teile Nr.	Beschreibung
69	1	SG947315231160	Feder

Illustration Grasfangkorb

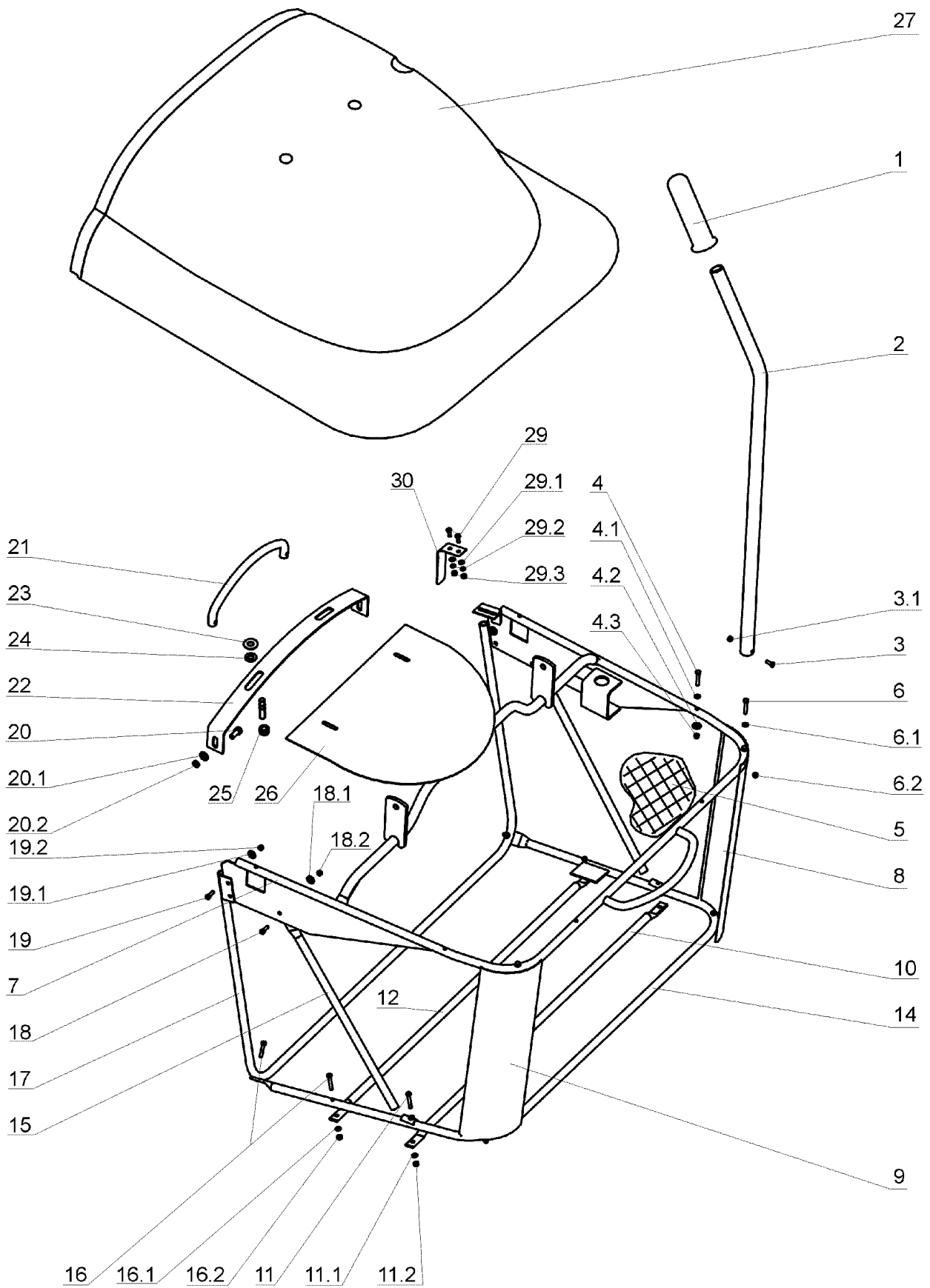

## Illustration    Grasfangkorb

Bild Nr.	St.- Zahl	Teile Nr.	Beschreibung
1	1	SG947532150007	Handgriff
2	1	SG532074202013	Hebel
3	1	SG947309203548	Schraube
3.1	1	SG947311129515	Sichermutter
4	6	SG947309203555	Sechskantschraube
4.1	6	SG947311212514	Scheibe
4.2	6	SG947311210501	Scheibe
4.3	6	SG947311129515	Sichermutter
5	1	SG947532150256	Aschluss
6	4	SG947309203557	Sechskantschraube
6.1	4	SG947311210501	Scheibe
6.2	4	SG947311129515	Sichermutter
7	1	SG532974472373	Rahmen
8	1	SG532074422263	Halter
9	1	SG532074422273	Halter
10	1	SG532074262083	Rohr
11	2	SG947309203556	Sechskantschraube
11.1	2	SG947311210501	Scheibe
11.2	2	SG947311129515	Sichermutter
12	1	SG532074262073	Rahmen
14	1	SG532974462063	Rahmen
15	2	SG532074262063	Halter
16	4	SG947309203555	Sechskantschraube
16.1	4	SG947311210501	Scheibe
16.2	4	SG947311129515	Sichermutter
17	1	SG532974442033	Rahmen
18	2	SG947309203539	Schraube
18.1	2	SG947311210501	Scheibe
18.2	2	SG947311129515	Sichermutter
19	4	SG947309019514	Schraube
19.1	4	SG947311212514	Scheibe
19.2	4	SG947311129515	Sichermutter
20	2	SG947309203504	Schraube
20.1	2	SG947311214502	Scheibe
20.2	2	SG947311210503	Scheibe
21	1	SG532913462503	Handgriff
22	1	SG532015408053	Halter
23	2	SG947311212040	Scheibe
24	4	SG947311210504	Scheibe
25	2	SG947311129502	Mutter
26	1	SG532085406193	Schultz
27	1	SG947532150272	Deckel
29	2	SG947309203548	Schraube
29.1	2	SG947311210501	Scheibe
29.2	2	SG947311214507	Scheibe
29.3	2	SG947311129515	Sichermutter

Illustration Grasfangkorb

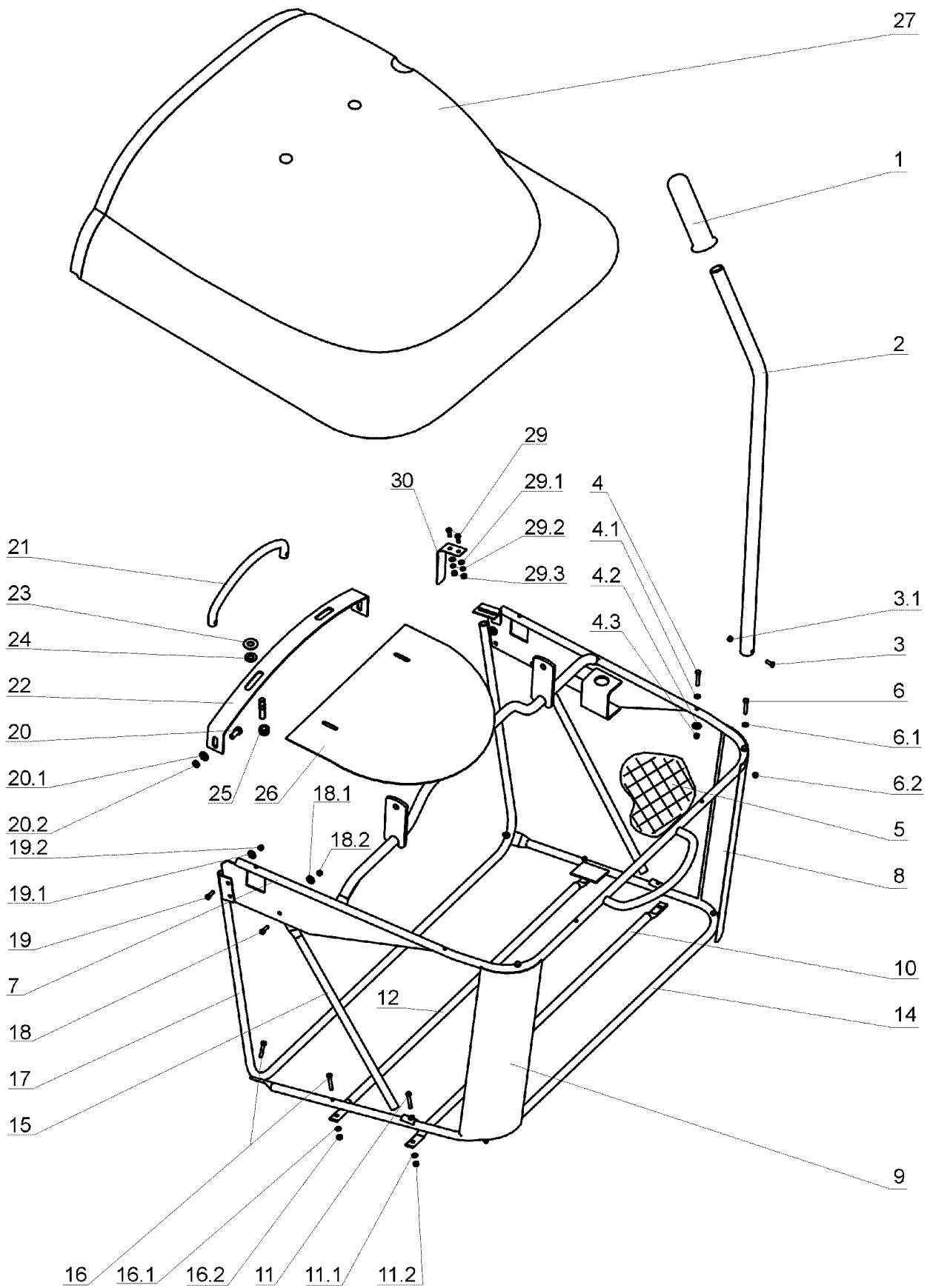

## Illustration    Grasfangkorb

---

Bild Nr.	St.- Zahl	Teile Nr.	Beschreibung
30	2	SG532097402163	Kontakt



# Illustration Hinterachse

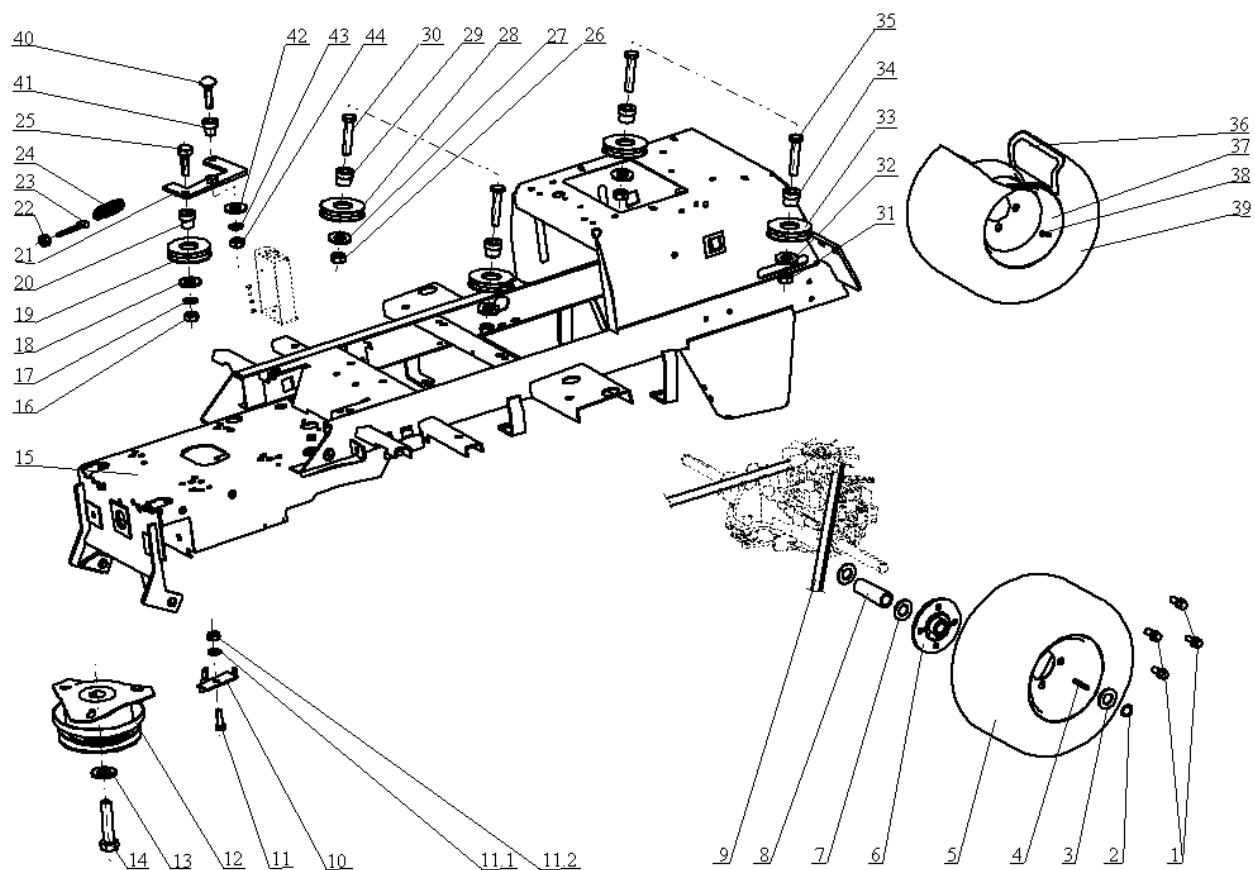

## Illustration    Hinterachse

---

Bild Nr.	St.- Zahl	Teile Nr.	Beschreibung
1	8	SG947443900092	Schraube
2	2	SG947311733014	Kobelring
3	4	SG532092208053	Scheibe
4	2	SG532092312203	Feder
5	2	SG947532940087	Rad
6	2	SG532029214303	Deckel
7	15	SG532092208083	Scheibe
8	2	SG532195203523	Buchse
9	1	SG947272731200	Riemen
10	1	SG532936362163	Führung
11	1	SG947309203504	Schraube
11.1	1	SG947311214502	Scheibe
11.2	1	SG947311120502	Mutter
12	1	SG947000532010	Kupplung
12	1	SG947339242006	Kupplung
13	1	SG947311214012	Scheibe
14	1	SG947309579509	Schraube
15	1	SG532912962633	Rahmen
16	1	SG947311120503	Sechskantmutter
17	1	SG947311214503	Scheibe
18	1	SG947311210504	Scheibe
19	1	SG947000532003	Scheibe
20	1	SG947532150544	Buchse
21	1	SG532913322763	Halter
22	1	SG947311129513	Sichermutter
23	1	SG947309578523	Schraube
24	1	SG947315231111	Feder
25	1	SG947309019528	Schraube
26	2	SG947311129502	Mutter
27	2	SG947311210504	Scheibe
28	2	SG947000532006	Scheibe
29	2	SG532094214183	Buchse
30	2	SG947309201512	Sechskantschraube
31	2	SG947311129502	Mutter
32	2	SG947311210504	Scheibe
33	2	SG947000532006	Scheibe
34	2	SG532094214473	Buchse
35	2	SG947309201523	Sechskantschraube
36	2	SG947000532133	Reifenschlauch
37	2	SG947325111019	Rad
38	2	SG947000532135	Ventil
39	2	SG947000532132	Reifen
40	1	SG947309203528	Schraube
41	1	SG947532150545	Buchse
42	1	SG947311210504	Scheibe
43	1	SG947311214503	Scheibe

---



## Illustration    Hinterachse

---

Bild Nr.	St.- Zahl	Teile Nr.	Beschreibung
44	1	SG947311120503	Sechskantmutter

# Illustration Kapotte (1/2)

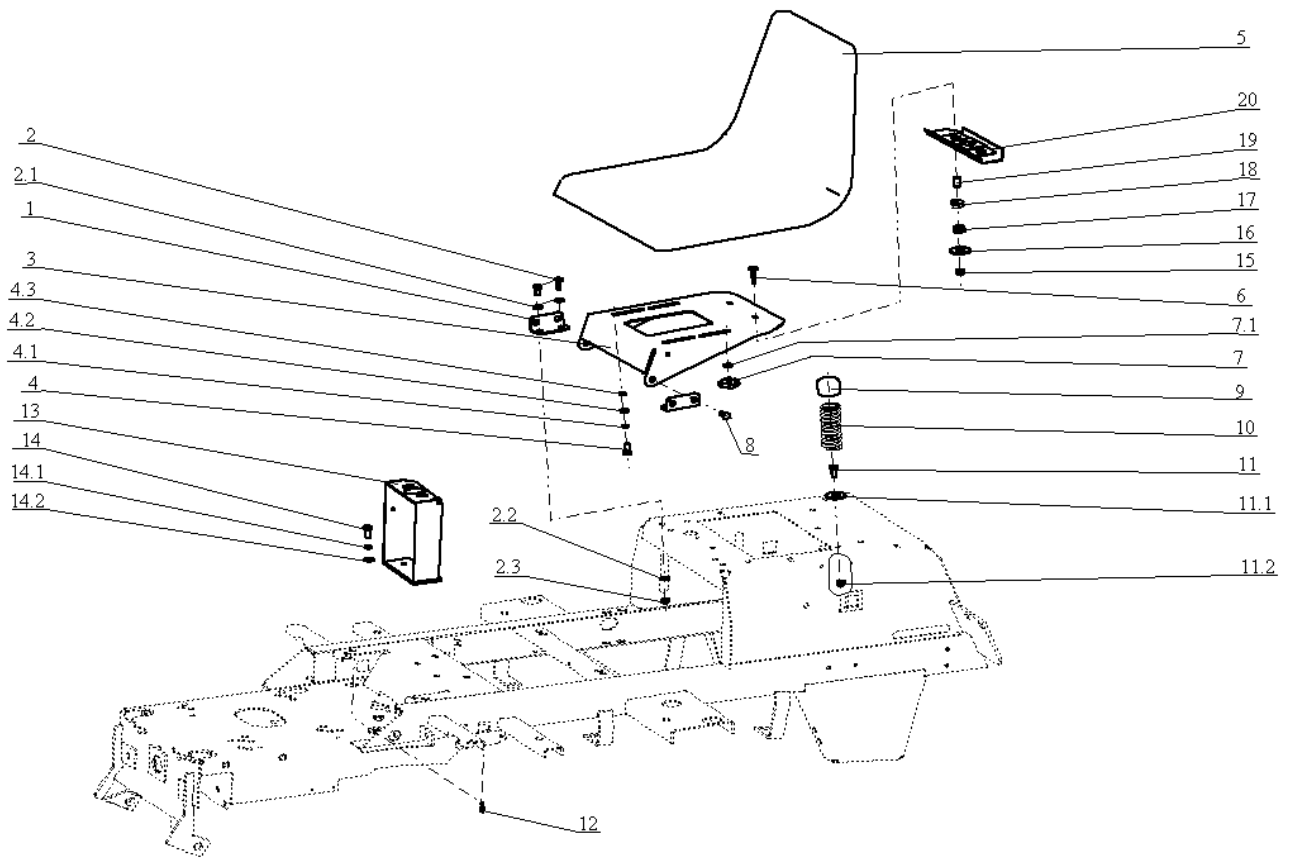

## Illustration Kapotte (1/2)

---

Bild Nr.	St.- Zahl	Teile Nr.	Beschreibung
1	2	SG532113402403	Halter
2	4	SG947309203504	Schraube
2.1	6	SG947311210503	Scheibe
2.2	6	SG947311214502	Scheibe
2.3	6	SG947311120502	Mutter
3	1	SG532018472433	Sitz
4	2	SG947309203504	Schraube
4.1	2	SG947311214502	Scheibe
4.2	2	SG947311210503	Scheibe
4.3	2	SG947311219002	Scheibe
5	1	SG947532150212	Sitz
6	2	SG947309019519	Schraube
7	2	SG947532150213	Mutter
7.1	2	SG947311213503	Scheibe
8	2	SG947309599012	Schraube
9	2	SG947532150208	Deckel
10	2	SG947315231124	Feder
11	2	SG947309203517	Sechskantschraube
11.1	2	SG947311212517	Scheibe
11.2	2	SG947311129501	Sichermutter
12	3	SG947425111004	Fettnippel
13	1	SG532916422023	Deckel
14	2	SG947309203504	Schraube
14.1	2	SG947311214502	Scheibe
14.2	2	SG947311210503	Scheibe
15	2	SG947311129513	Sichermutter
16	2	SG947311212520	Scheibe
17	2	SG947722643019	Buchse
18	2	SG947315231194	Feder
19	2	SG947532150442	Distanzstück
20	1	SG532983362153	Bride

# Illustration Kapotte (2/2)

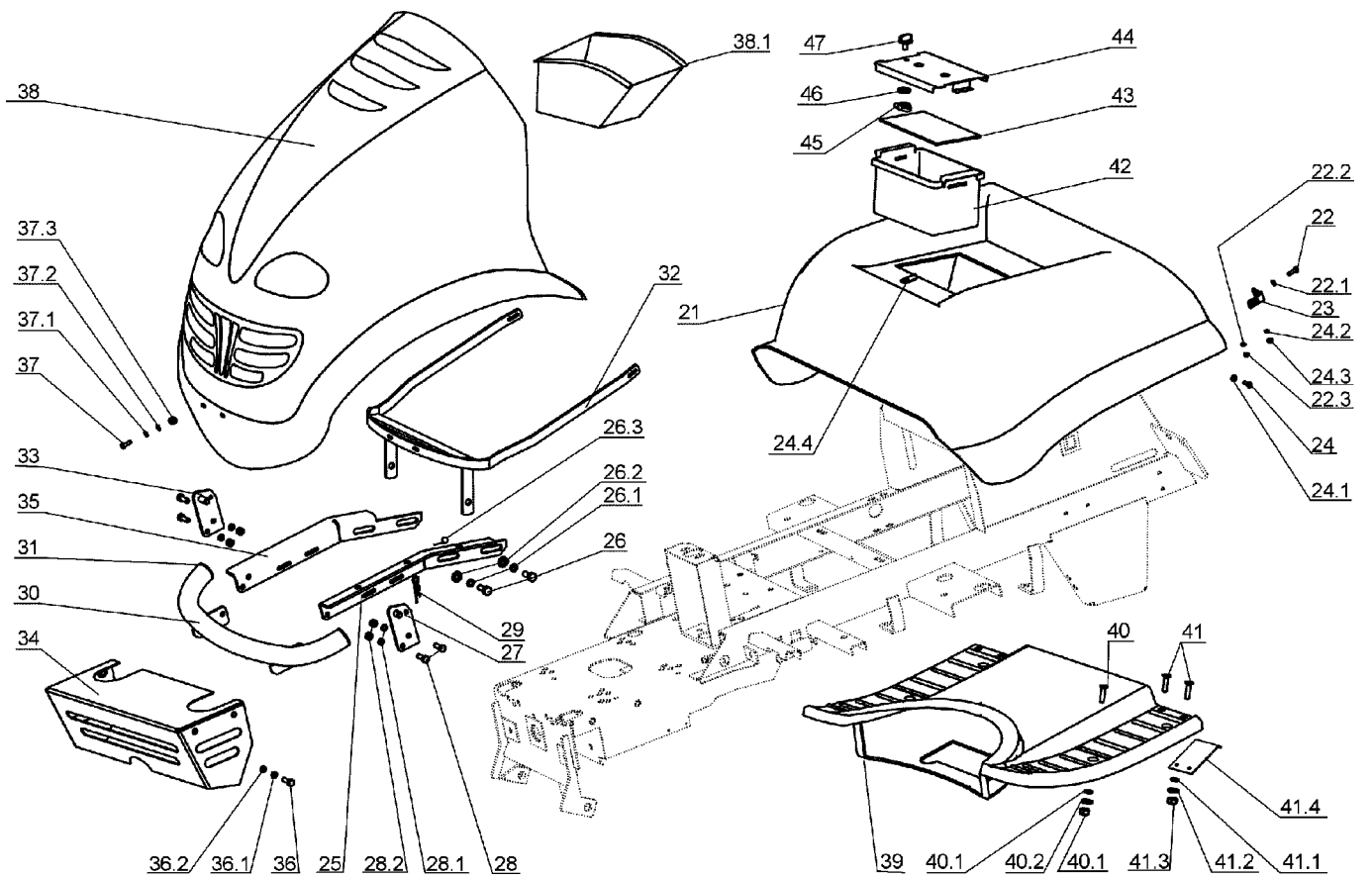

## Illustration Kapotte (2/2)

Bild Nr.	St.- Zahl	Teile Nr.	Beschreibung
21	1	SG947532150637	Kotflügel
22	2	SG947309203539	Schraube
23	2	SG532014408153	Schienenfuss
24	2	SG947309019514	Schraube
25	1	SG532113413443	Bride
26	4	SG947309203516	Schraube
27	1	SG532913368243	Halter
28	4	SG947309203517	Sechskantschraube
29	1	SG947315238005	Ring
30	1	SG532918462133	Rohr
31	2	SG947321841068	Flansch
32	1	SG532913473503	Halter
33	1	SG532913368233	Halter
34	1	SG532985423333	Deckel
35	1	SG532113413433	Bride
36	4	SG947309203501	Sechskantschraube
37	4	SG947309019520	Schraube
38	1	SG532918492843	Haube
39	4	SG947309019520	Schraube
40	1	SG947532150428	Schraube
41	6	SG947309019501	Schraube
42	1	SG532086422333	Werkzeugkasten
43	1	SG532199303413	Scheibe
44	1	SG532086422323	Deckel
45	1	SG947532150110	Hebel
46	1	SG947311219515	Scheibe
47	1	SG947532150209	Stecker
22.1	2	SG947311212514	Scheibe
22.2	2	SG947311214507	Scheibe
22.3	2	SG947311120506	Mutter
24.1	2	SG947311212514	Scheibe
24.2	2	SG947311214507	Scheibe
24.3	2	SG947311120506	Mutter
26.1	4	SG947311214503	Scheibe
26.2	4	SG947311212521	Scheibe
26.3	1	SG947321841071	Klammer
28.1	4	SG947311214502	Scheibe
28.2	4	SG947311120502	Mutter
36.1	4	SG947311214501	Scheibe
36.2	4	SG947311210502	Scheibe
37.1	4	SG947311212511	Scheibe
37.2	4	SG947311214507	Scheibe
37.3	4	SG947311120506	Mutter
38.1	2	-	Nicht verfügbar für diesen produkt
41.1	6	SG947311210503	Scheibe
41.2	6	SG947311214502	Scheibe



Illustration Kapotte (2/2)

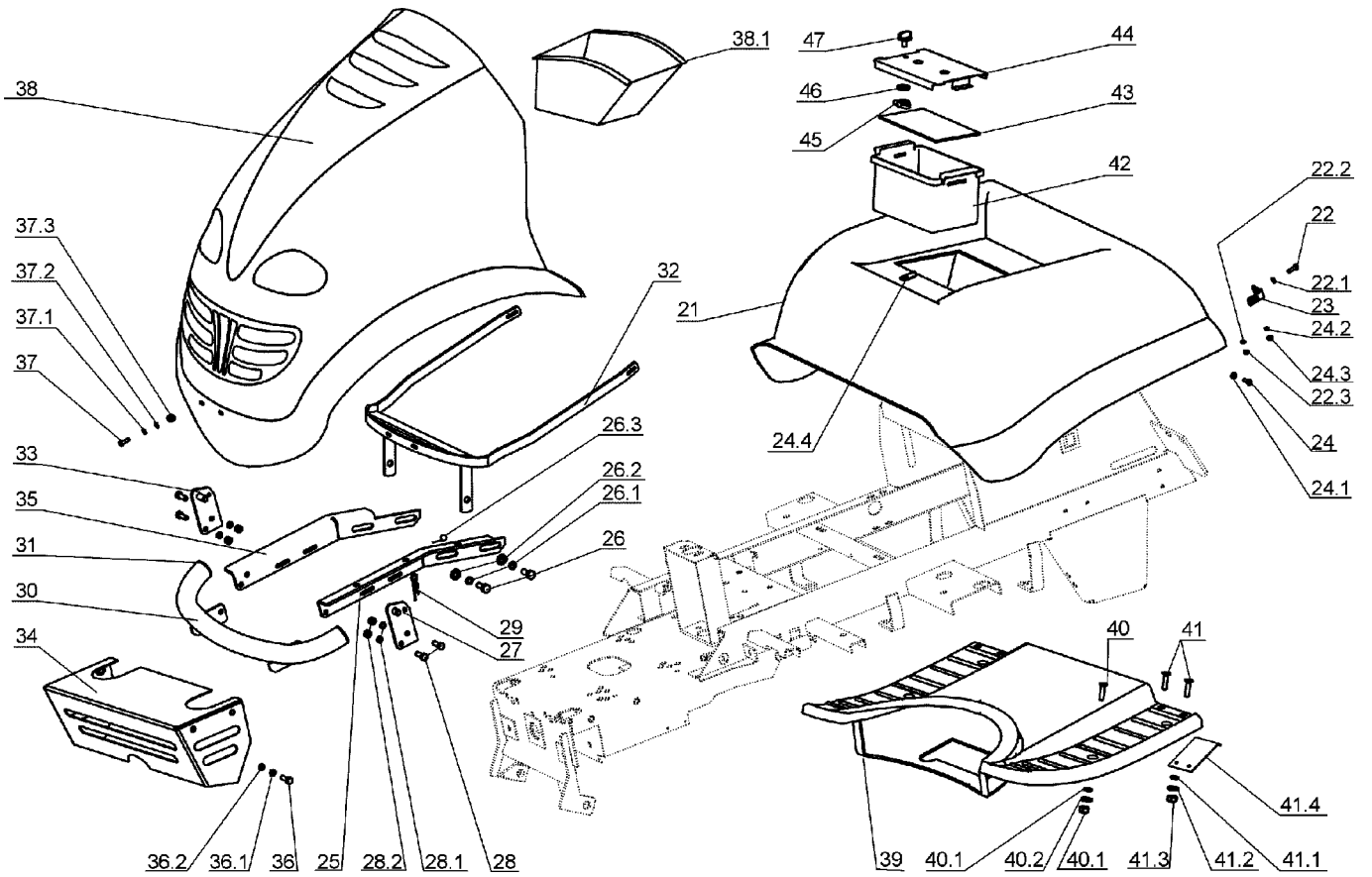

## Illustration Kapotte (2/2)

---

Bild Nr.	St.- Zahl	Teile Nr.	Beschreibung
41.3	6	SG947311120502	Mutter
41.4	2	-	Nicht verfügbar für diesen produkt

Illustration Kapottepanel

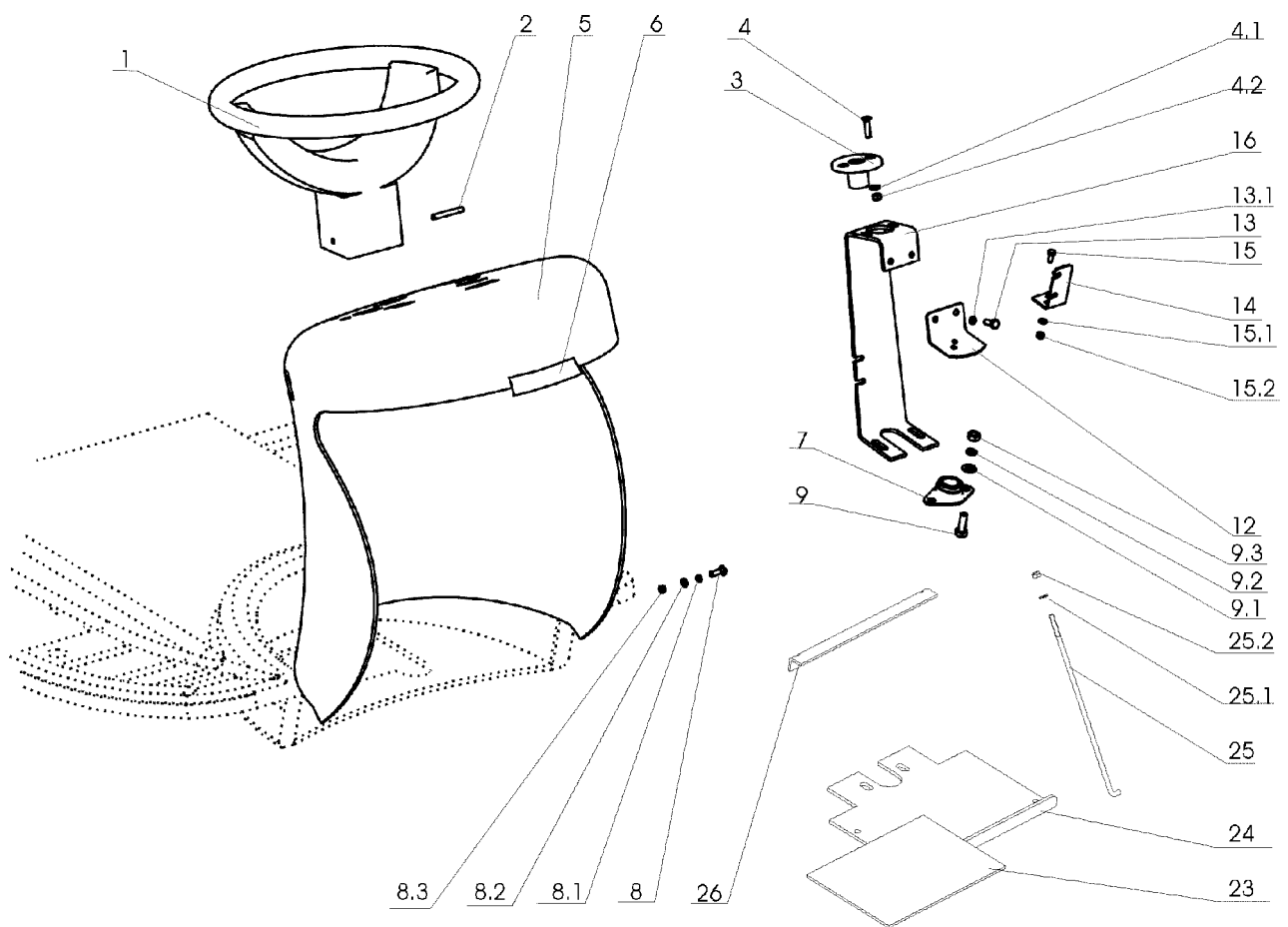

## Illustration Kapottepanel

---

Bild Nr.	St.- Zahl	Teile Nr.	Beschreibung
1	1	SG947443821003	Lenkrad
2	1	SG947315238031	Splint
3	1	SG947321841069	Buchse
4	2	SG947309578503	Schraube
4.1	2	SG947311210502	Scheibe
4.2	2	SG947311129513	Sichermutter
5	1	SG947532150429	Blechtafel
6	1	SG532096342133	Dichtung
7	1	SG947000324001	Lager
8	4	SG947309019520	Schraube
8.1	4	SG947311212511	Scheibe
8.2	4	SG947311214507	Scheibe
8.3	4	SG947311120506	Mutter
9	2	SG947309203517	Sechskantschraube
9.1	2	SG947311210503	Scheibe
9.2	2	SG947311214502	Scheibe
9.3	2	SG947311120502	Mutter
12	1	SG532113404253	Halter
13	2	SG947309203501	Sechskantschraube
13.1	2	SG947311214501	Scheibe
14	1	SG532113403293	Halter
15	2	SG947309203548	Schraube
15.1	2	SG947311210501	Scheibe
15.2	2	SG947311129515	Sichermutter
16	1	SG532913413053	Halter
23	1	SG532096303073	Scheibe
24	1	SG532113413923	Halter
25	2	SG947532150464	Leiter
25.1	2	SG947311210501	Scheibe
25.2	2	SG947311129515	Sichermutter
26	1	SG532113403243	Halter

# Illustration Lenkgetriebe

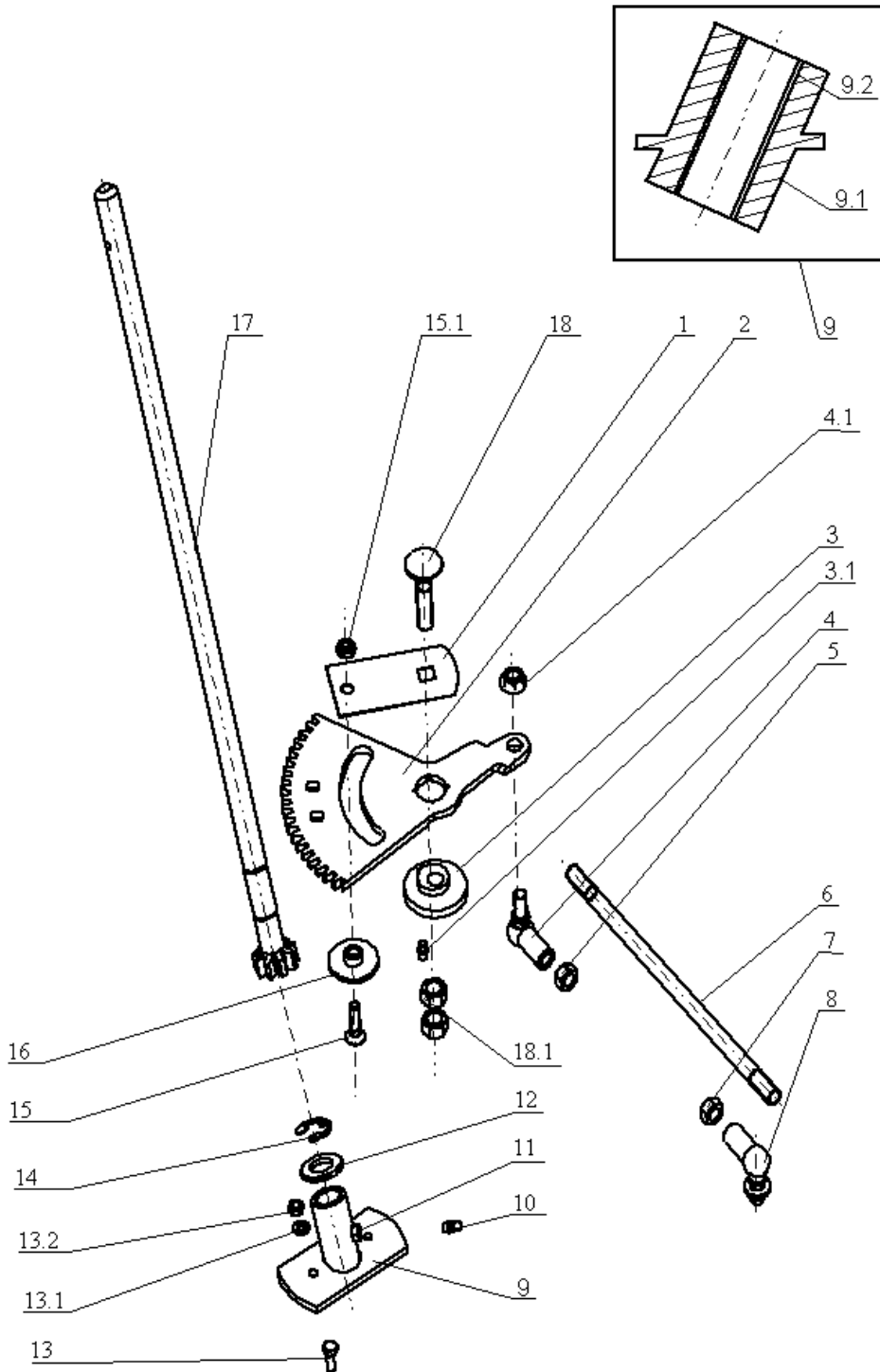

## Illustration Lenkgetriebe

---

Bild Nr.	St.- Zahl	Teile Nr.	Beschreibung
1	1	SG532113322803	Platte
2	1	SG532033322083	Zahnrad
3	1	SG532080272033	Exzenter
3.1	1	SG947425111004	Fettnippel
4	1	SG947442073019	Dichtung
4.1	2	SG947311129521	Mutter
5	1	SG947311120539	Mutter
6	1	SG947532980125	Spannstange
7	1	SG947311120504	Sechskantmutter
8	1	SG947442073020	Dichtung
9	1	SG532938703433	Halter
9.1	1	SG532938542043	Halter
9.2	1	SG947323721002	Buchse
10	1	SG947425111004	Fettnippel
11	1	SG947311210530	Scheibe
12	1	SG947311210514	Scheibe
13	2	SG947309503557	Sechskantschraube
13.1	2	SG947311212516	Scheibe
13.2	2	SG947311129513	Sichermutter
14	1	SG947311732008	Kobelring
15	1	SG947309578506	Schraube
15.1	1	SG947311120520	Mutter
16	1	SG947532150538	Distanzstück
17	1	SG532930252113	Zahnrad
18	1	SG947309019522	Schraube
18.1	2	SG947311120504	Sechskantmutter

# Illustration Mäheraushebung-schaltung

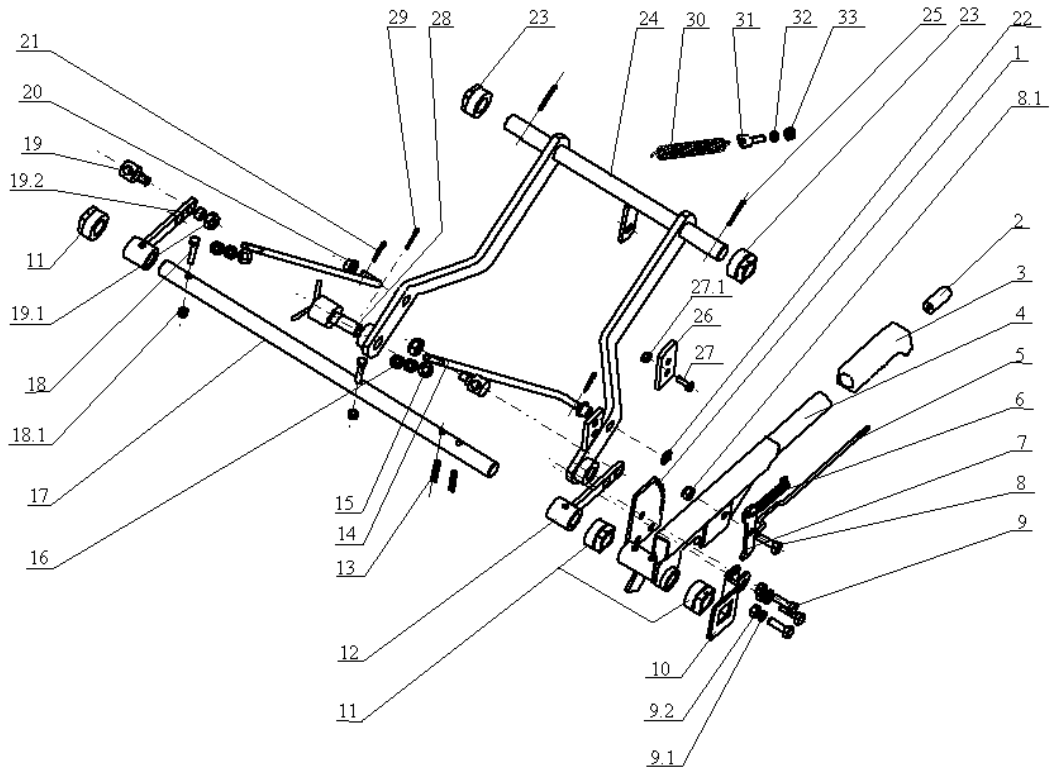

## Illustration Mäheraushebung-schaltung

Bild Nr.	St.- Zahl	Teile Nr.	Beschreibung
1	1	SG532037322183	Zahnrad
2	1	SG947722643016	Schalter
3	1	SG947532150049	Handgriff
4	1	SG532980522163	Hebel
5	1	SG947315238034	Pleuel
6	1	SG947315231158	Feder
7	1	SG947532150641	Klinke
8	1	SG947309203517	Sechskantschraube
8.1	1	SG947311129501	Sichermutter
9	3	SG947309503512	Schraube
9.1	3	SG947311214502	Scheibe
9.2	3	SG947311120502	Mutter
10	1	SG532113414183	Halter
11	3	SG947722643022	Buchse
12	2	SG532980462853	Arm
13	2	SG947315238041	Feder
14	2	SG532080402683	Hebel
15	2	SG947311210503	Scheibe
16	4	SG947311120502	Mutter
17	1	SG532038102853	Welle
18	2	SG947309501568	Schraube
18.1	2	SG947311129513	Sichermutter
19	2	SG947532150507	Schraube
19.1	2	SG947311129502	Mutter
19.2	2	SG532195203273	Distanzstück
20	2	SG947532150537	Ring
21	2	SG947311338516	Splint
22	2	SG947311210503	Scheibe
23	2	SG947722643022	Buchse
24	1	SG532980508103	Hebel
25	2	SG947311338517	Splint
26	1	SG532114327223	Kupplungsblock
27	2	SG947309578522	Schraube
27.1	2	SG947311129501	Sichermutter
28	2	SG532993462153	Stift
29	2	SG947315238003	Ring
30	1	SG947315231165	Feder
31	1	SG947309599018	Schraube
32	1	SG947311214503	Scheibe
33	1	SG947311120503	Sechskantmutter



Illustration Motor

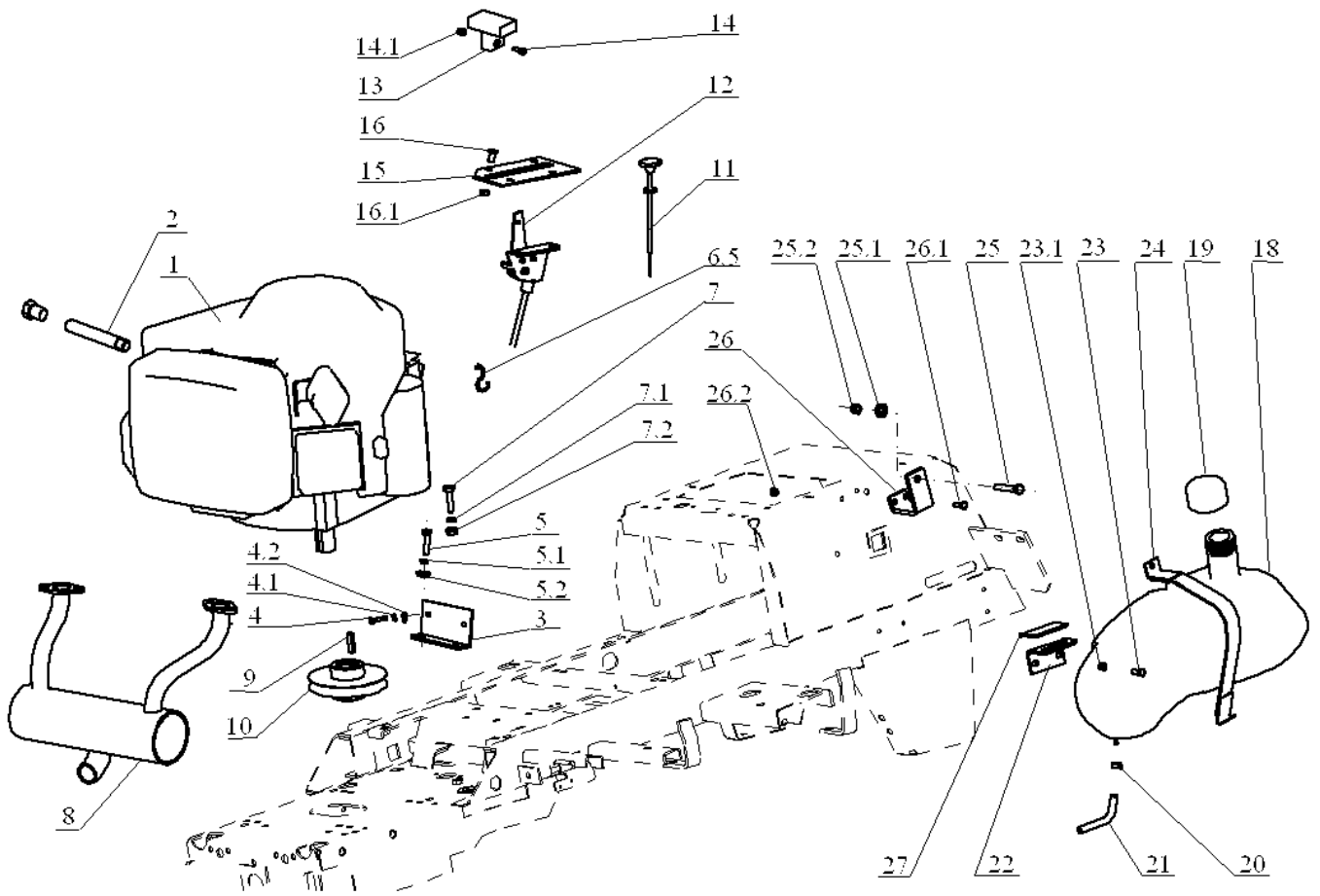

## Illustration    Motor

---

Bild Nr.	St.- Zahl	Teile Nr.	Beschreibung
2	1	SG532927262053	Verlaengerung
3	1	SG532913402933	Halter
4	2	SG947309503548	Sechskantschraube
4.1	2	SG947311214501	Scheibe
4.2	2	SG947311210502	Scheibe
5	2	SG947309503559	Sechskantschraube
5.1	2	SG947311214502	Scheibe
5.2	2	SG947311212517	Scheibe
7	4	SG947309203564	Sechskantschraube
7.1	4	SG947311214502	Scheibe
7.2	4	SG947311150503	Mutter
8	1	SG532927472303	Auspufftopt
9	1	SG532092312153	Schlüssel
10	1	SG947000532012	Scheibe
11	1	SG947443612013	Hebel
12	1	SG947443900095	Gashebel
13	1	SG947443900093	Gashebel
14	1	SG947309231505	Schraube
14.1	1	SG947311129514	Mutter
15	1	SG532115309553	Halter
16	4	SG947309251514	Schraube
16.1	4	SG947311129515	Sichermutter
18	1	SG532927702203	Tank
19	1	SG947321841017	Stopfen
20	2	SG947000532058	Klammer
21	1	SG532199202463	Schlauch
22	1	SG532113404223	Halter
23	2	SG947309503548	Sechskantschraube
23.1	2	SG947311129513	Sichermutter
24	1	SG532913422643	Halter
25	1	SG947309543514	Schraube
25.1	2	SG947311210503	Scheibe
25.2	1	SG947311120502	Mutter
26	1	SG532013425133	Halter
26.1	2	SG947309503548	Sechskantschraube
26.2	2	SG947311129513	Sichermutter
27	1	SG947273445012	Sitz

Illustration Schneidwerkzeug (1/2)

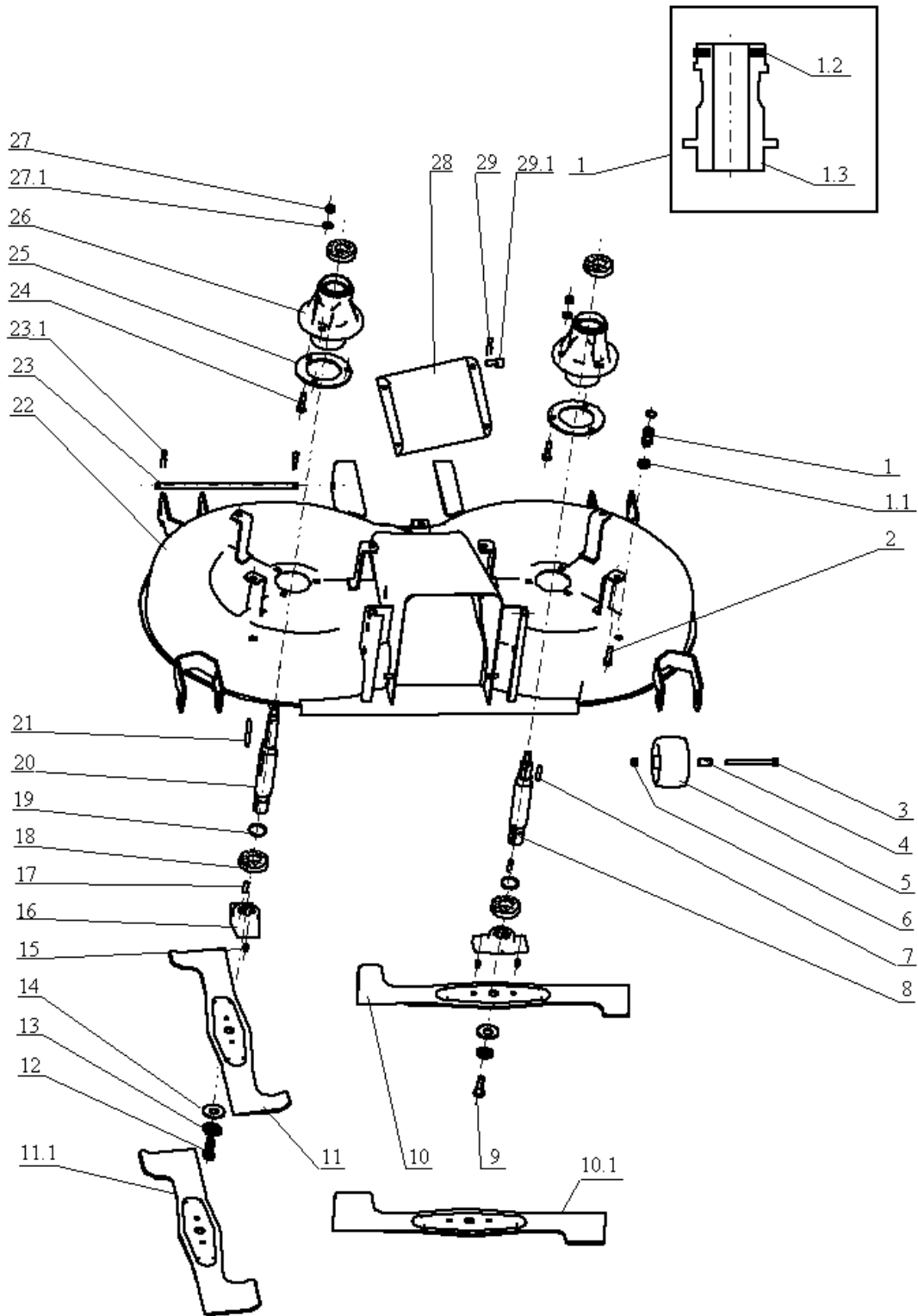

## Illustration    Schneidwerkzeug (1/2)

---

Bild Nr.	St.- Zahl	Teile Nr.	Beschreibung
1	2	SG532990362343	Kupplung
1.1	2	SG947311120511	Sechskantmutter
1.2	2	SG947273111054	Ring
1.3	2	SG947532150533	Kupplung
2	6	SG947309503518	Schraube
3	4	SG947309201524	Sechskantschraube
4	4	SG947532150539	Distanzstück
5	4	SG947532940114	Walze
6	4	SG947311129501	Sichermutter
7	1	SG947311726009	Schlüssel
8	1	SG532038128023	Welle
9	1	SG947309599008	Schraube
10	1	SG532050422543	Blatt
10.1	1	SG532050422483	Blatt
11	1	SG532050422533	Blatt
11.1	1	SG532050422473	Blatt
12	1	SG947309599017	Sechskantschraube
13	2	SG947532150519	Scheibe
14	2	SG947311219503	Scheibe
15	4	SG947532980077	Stift
16	2	SG532098212403	Anpassungsglied
17	2	SG947311726014	Schlüssel
18	4	SG947324162099	Lager
19	2	SG947311733014	Kobelring
20	1	SG532038128033	Welle
21	1	SG947311726019	Schlüssel
22	1	SG532950472083	Deck
23	1	SG532193102893	Stift
23.1	2	SG947315238035	Stift
24	6	SG947309503543	Sechskantschraube
25	2	SG532098203373	Dichtung
26	2	SG532038523833	Deckel
27	6	SG947311129501	Sichermutter
27.1	6	SG947311210503	Scheibe
28	1	SG532080503503	Einstellen
29	2	SG947315238003	Ring
29.1	2	SG947311613002	Stift

Illustration Schneidwerkzeug (2/2)

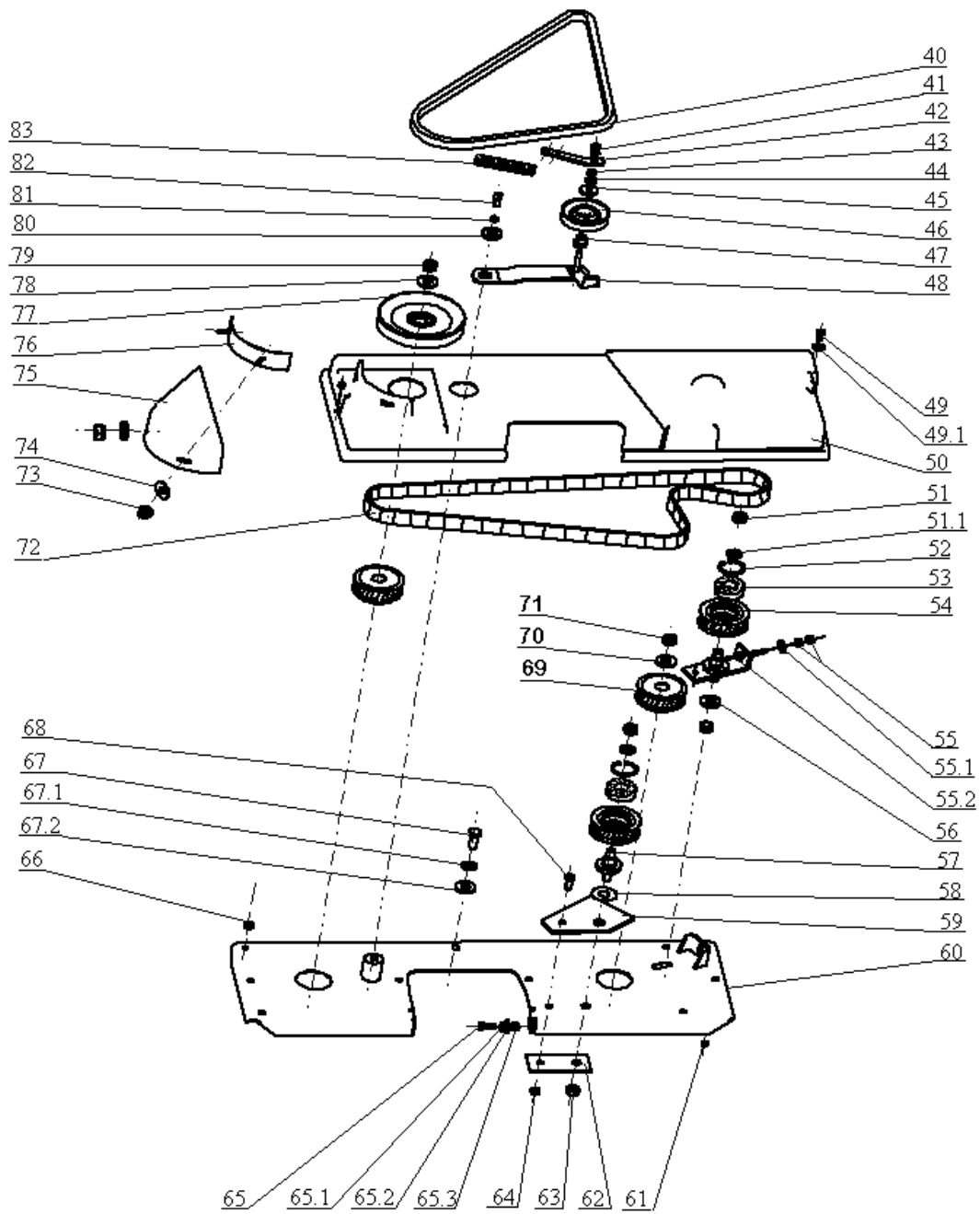

## Illustration    Schneidwerkzeug (2/2)

Bild Nr.	St.- Zahl	Teile Nr.	Beschreibung
40	1	SG947272731192	Riemen 17x1400
41	2	SG947311120520	Mutter
42	1	SG532113402353	Hebel
43	1	SG947311120502	Mutter
44	1	SG947311214502	Scheibe
45	1	SG947311212508	Scheibe
46	1	SG947000532002	Scheibe
47	1	SG947532150517	Stift
48	1	SG532913422403	Hebel
49	2	SG947309503557	Sechskantschraube
49.1	4	SG947311212516	Scheibe
50	1	SG947532150210	Riemendeckel
51	2	SG947311129505	Sichermutter
51.1	2	SG947311210505	Scheibe
52	2	SG947311733079	Ring
53	2	SG947324162098	Lager
54	2	SG532933712743	Scheibe
55	2	SG947311120502	Mutter
55.1	1	SG947311212517	Scheibe
55.2	1	SG532914412313	Mutter
56	1	SG532092207533	Scheibe
57	1	SG532993122683	Stift
58	1	SG532092207703	Scheibe
59	1	SG532096303973	Halter
60	1	SG532985423313	Platte
61	2	SG947311129513	Sichermutter
62	1	SG532092303963	Halter
63	2	SG947311129505	Sichermutter
64	1	SG947311129501	Sichermutter
65	2	SG947309019501	Schraube
65.1	2	SG947311210505	Scheibe
65.2	2	SG947311210503	Scheibe
65.3	2	SG947311129501	Sichermutter
66	6	SG947311129501	Sichermutter
67	1	SG947309503518	Schraube
67.1	1	SG947311214502	Scheibe
67.2	1	SG947311210503	Scheibe
68	1	SG947309203517	Sechskantschraube
69	2	SG532933712773	Scheibe
70	1	SG947532150645	Scheibe
71	1	SG947311129505	Sichermutter
72	1	SG947272211006	Riemen
73	2	SG947311129513	Sichermutter
74	2	SG947311212516	Scheibe
75	1	SG947532150559	Deckel
76	1	SG532985402733	Dichtung

Illustration Schneidwerkzeug (2/2)

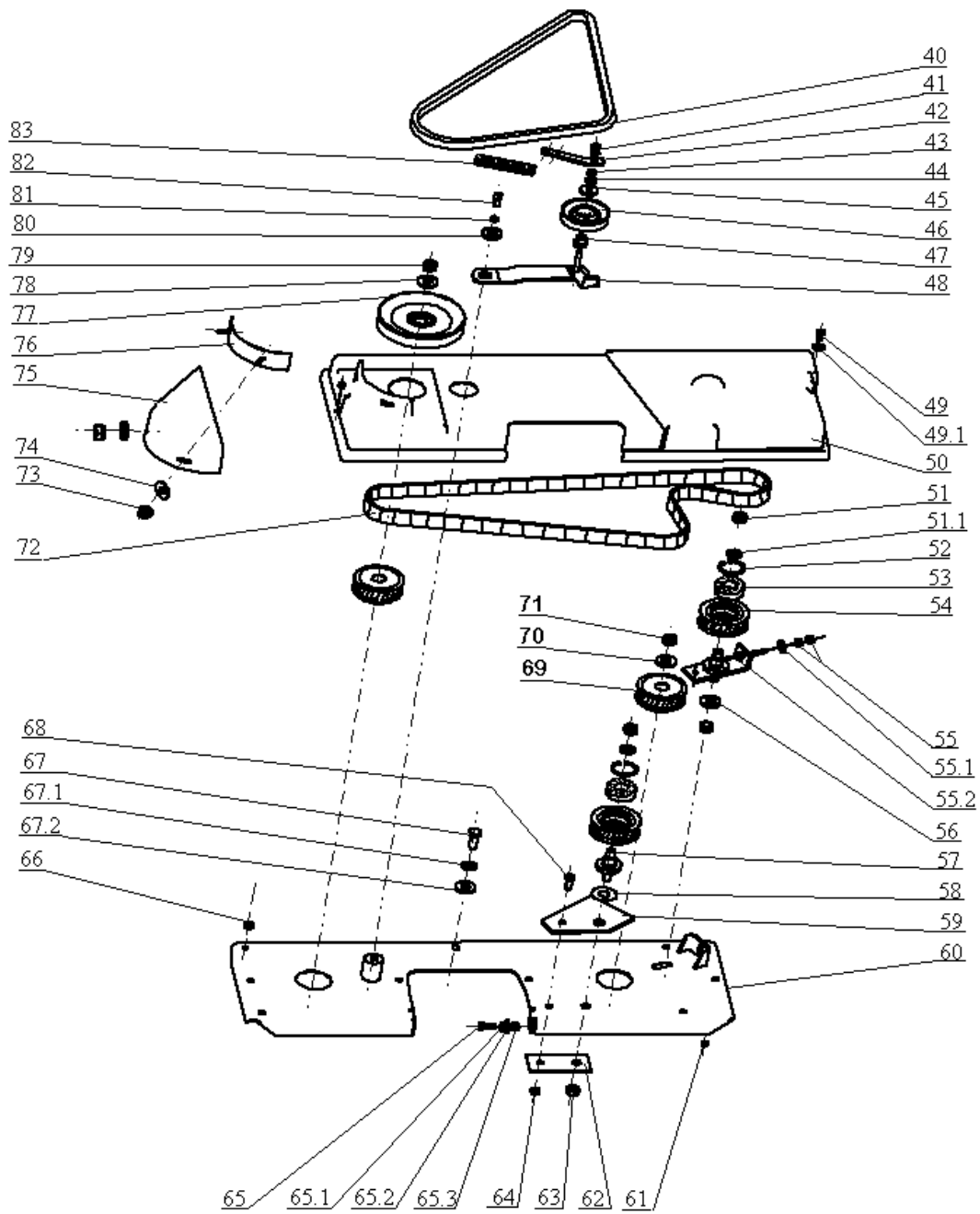

## Illustration    Schneidwerkzeug (2/2)

---

Bild Nr.	St.- Zahl	Teile Nr.	Beschreibung
77	1	SG947532150164	Scheibe
78	1	SG532092207273	Scheibe
79	1	SG947311129505	Sichermutter
80	1	SG947532150520	Scheibe
81	1	SG947311214502	Scheibe
82	1	SG947309543506	Sechskantschraube
83	1	SG947315231193	Feder



# Illustration Vorderachse

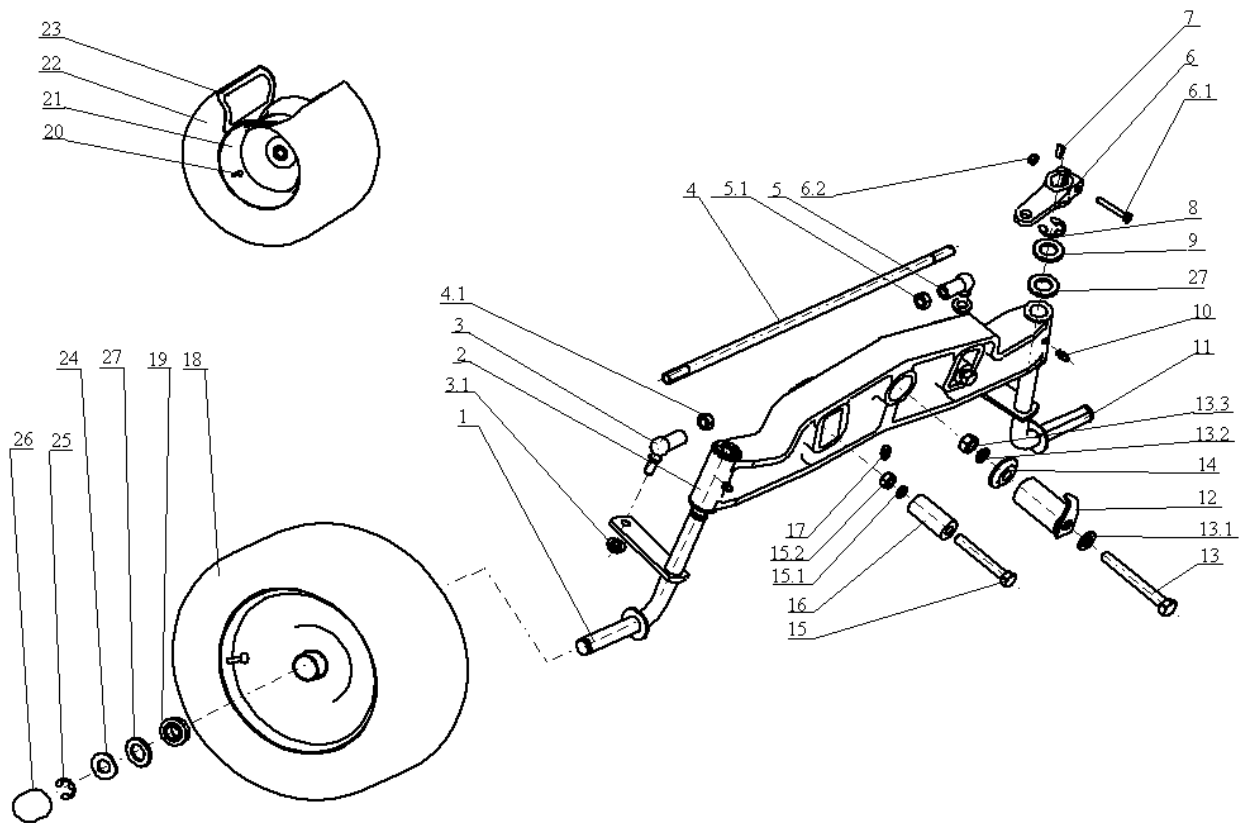

## Illustration Vorderachse

Bild Nr.	St.- Zahl	Teile Nr.	Beschreibung
1	1	SG532916432153	Stift
2	1	SG532016542063	Vorn achse
3	1	SG947442073020	Dichtung
3.1	2	SG947311129521	Mutter
4	1	SG947532980126	Spannstange
4.1	1	SG947311120504	Sechskantmutter
5	1	SG947442073019	Dichtung
5.1	1	SG947311120539	Mutter
6	1	SG532080503603	Hebel
6.1	1	SG947309203524	Sechskantschraube
6.2	1	SG947311129513	Sichermutter
7	1	SG947311728003	Schlüssel
8	2	SG947311732008	Kobelring
9	4	SG947311210514	Scheibe
10	2	SG947425111004	Fettnippel
11	1	SG532016432143	Stift
12	1	SG532993164373	Stift
13	1	SG947309501534	Sechskantschraube
13.1	1	SG947311210505	Scheibe
13.2	1	SG947311214504	Scheibe
13.3	1	SG947311120504	Sechskantmutter
14	1	SG947532150518	Scheibe
15	2	SG947309201540	Sechskantschraube
15.1	2	SG947311214503	Scheibe
15.2	2	SG947311120503	Sechskantmutter
16	2	SG947532150543	Buchse
17	1	SG947425111016	Fettnippel
18	2	SG947532940113	Rad
19	4	SG947324196015	Halter
20	2	SG947000532135	Ventil
21	2	SG947000532124	Rad
22	2	SG947000532123	Reifen
23	2	SG947000532125	Reifenschlauch
24	2	SG532092207393	Scheibe
25	2	SG947311732008	Kobelring
26	2	SG947532150208	Deckel
27	8	SG532092208153	Scheibe